

# Shush®

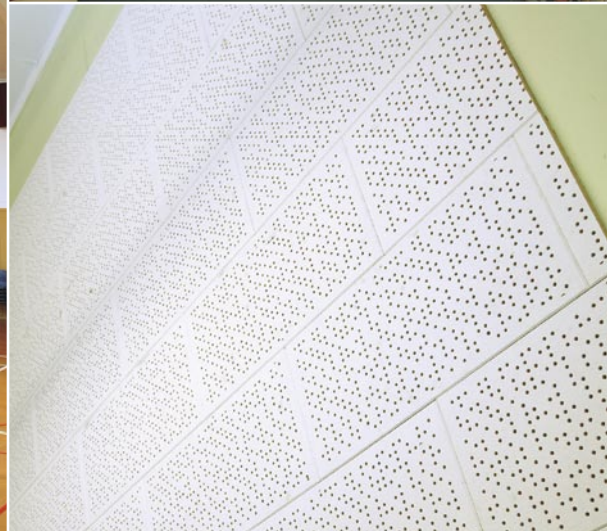

another trade essential from  
THE **laminex** GROUP™

# Introduction

Trade Essentials® Shush® are acoustic wall and ceiling linings.

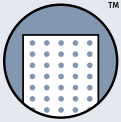

**Shush®**

## Product Description

A wood fibre tongue and groove acoustic panel product for use in areas where acoustic properties are required.

### Create a Favourable Learning Environment

Common classroom noises like scraping chairs, children talking and whirring computers all affect a child's ability to learn.

Recent research by the OTICON FOUNDATION, Classroom Acoustics: A New Zealand Perspective confirms that Shush® Acoustic Linings do a very effective job of absorbing such noises, creating a better classroom learning environment for children.

### Create an Improved Working Environment for Teachers

- Vocal Strain is a serious occupational hazard for teachers. It occurs because they need to speak for long periods of time at an elevated voice level.
- Installing Shush® Acoustic Linings in classroom ceiling reduces learning area noises, allowing teachers to speak at a more normal level.
- The result is less stress on a teacher's voice.

### Acoustic Tiles:

A tile manufactured for applications where acoustic performance is required. The tile has a system of holes in the surface of the tile which absorb the sound. Acoustic tiles are pre-primed.

### Fire Retardant Acoustic Tiles:

A tile manufactured for applications where acoustic and fire retardant properties are required. The tile has a system of holes in the surface of the tile which absorb sound and painted with a fire retardant intumescent paint that fills in the sound absorbing holes during the extremely high temperatures before a fire starts, making your room extra safe.

### Why Do Shush Acoustic Linings Absorb Sound:

The system of holes in the surface of the tile allows sound to enter. Once inside sound bounces around and is absorbed by the soft fibrous core.

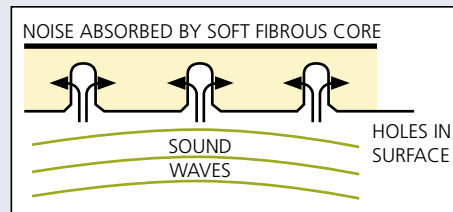

## Uses

- o New ceilings
- o Relining existing ceilings
- o Lowering ceilings
- o Panels within an exposed beam ceiling system

## Features

- o Textured surface
- o Fire retardant
- o Lightweight
- o Sound absorbing
- o Prevent heat loss
- o Environmentally friendly

## Benefits

- o Ideal for modernising homes and offices
- o Assists in family safety in case of fire
- o Easy to install
- o Made from 100% renewable resources

## Product Details

### Composition

Wood fibre ceiling panels are made from wood fibre pulp which, with bonding and water resistant additives, is reconstituted on a continuous forming line into a wet mat. The mat is pressed and dried to produce a low density insulation board characterised by a structure of long fibres and having a large proportion of minute voids. This structure gives the board its thermal insulation and sound absorbing qualities as well as the fine variable textured surface.

An automatic sequence of sawing, profiling and coating processes converts sheets in board form to panels which are tongue and grooved on four edges.

### Acoustic Tiles and Fire Retardant Acoustic Tiles

The panels are surface drilled to produce a sound absorbing surface. These tiles are available in Flame Retardant paint finish with a factory applied intumescent paint or a plain white undercoat finish.

### Durability

Shush Acoustic Linings, when handled, installed and maintained in accordance with this document will meet the provisions of NZBC B2.3.1(c), for 5 years.

### Limitations

Shush Acoustic Linings are designed and manufactured for interior applications only. This product requires an additional paint coating to be applied for final finishing.

Table 1 - Panel and Tile Sizes, Weights and Density.

Product	Nominal Size (mm)	Thickness (mm)	Panels Per Pack	Weight Per Pack (kg)	Weight (kg/m <sup>2</sup> )	Density (kg/m <sup>3</sup> )
Acoustic Tiles*	600 x 300	13	25	19.5	4.0	300

\* Fire Retardant and Undercoated Only.

### Early Fire Hazard Properties

The indices quoted in Table 2 can be obtained with common finish paints over the factory applied fire retardant coatings.

Table 2 - Early Fire Hazard Properties

(Tested to AS1530)

Product	Spread of Flame Index (0-10)	Smoke Developed Index (0-10)
Acoustic Tiles (Undercoated)	7	4
Acoustic Tiles (Fire Retardant Undercoated)	0	5

### Moisture / Dimensional Stability

The base board, though sized during manufacture to repel water, reacts to humidity changes in a way that is similar to other wood products. To minimise these changes the board is preconditioned during manufacture.

Elevated temperatures to either side of the panels can cause distortion and shrinkage in line with that experienced with wood based materials.

Table 3 - Water Vapour Permeability

Permeance	23g/day m <sup>2</sup> mm Hg (ASTM C355-64)  Note: This figure improves considerably if the panels are finish coated with a high quality solvent based paint system.
-----------	--

### Scotia

Michelangelo Scotia is manufactured from the same low density insulating board and is designed to provide 55mm of cover, Michelangelo Scotia is undercoated white and available in three metre lengths. Michelangelo Scotia is profiled to the illustration in Fig. 1.

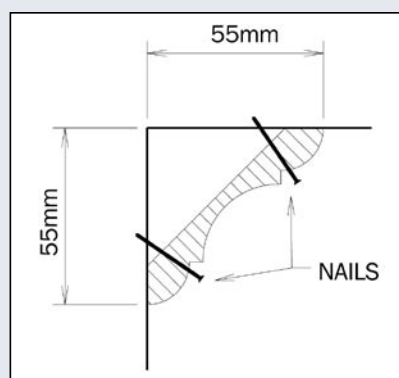

Figure 1. Michelangelo Scotia

## Installation

### Framing

To avoid panel distortion, moisture content of the framing must be below 18% at the time of tile and panel installation. This is especially important on large trusses or long joists as shrinkage may result in cramping of the battens causing the panels to bow and also shrink following compression at the edges. The building must be completely closed in with no green concrete, wet plaster or new brickwork within the enclosure.

Table 4 - Spans for Battens and Nail Size

Batten Size* (Nominal)	Span (mm)	Flathead Nails (mm)
50 x 25	Up to 600	1 x 60
50 x 40	Up to 900	2 x 75
75 x 40	Up to 1200	2 x 75

\* Battens at 300mm centres.

### Battens

The battens must be kiln dried and be below 18% moisture content to avoid shrinkage. Select the correct nail and batten size for spans between joists or bottom chords and trusses from Table 4.

To achieve a symmetrical effect the set out of the battens commences from the centre line of the room. Determine this point by measuring both ends of the room independently. The first batten will either be fixed over the room centre line or will be spaced half a panel width to one side, to achieve the maximum perimeter width for the outermost row.

The last batten on each side of the room is fastened against the wall. Refer Fig. 2.

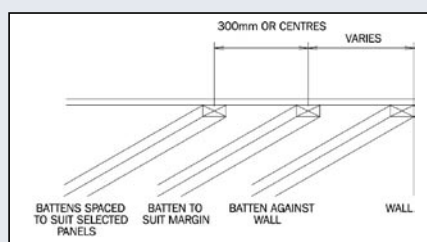

Figure 2. Batten Layout

## Set Out

Of the two basic layouts illustrated in Fig. 3, Ashlar is usually preferred both for eye appeal, ease and speed of installation. It will also minimise the effect of any variation in room size, uneven edge pressure when installing and counter the intersection of four corners meeting.

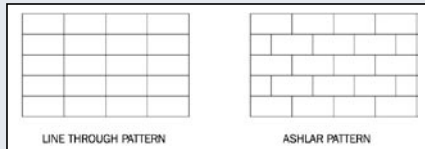

Figure 3. Panel and Tile Layout Patterns

Ensure ceiling margins are even, on opposite sides and opposite ends as illustrated in Fig. 4.

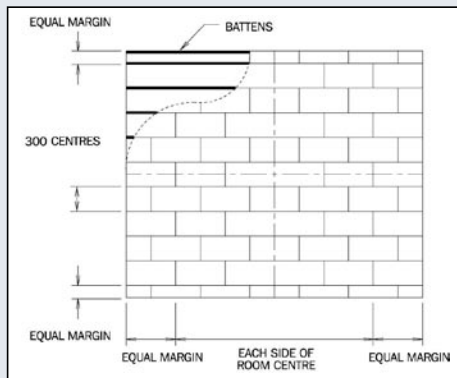

Figure 4. Layout Plan

- Measure along the batten on each side of the room to establish the second centre line.
- Run a chalk line between the marked points to set out for battens.
- Check that this line is at right angles to the battens.
- Measure out and mark 10mm from the mid point of the second batten from one wall, at both ends of the room.
- Run a chalk line between these points and mark along the batten.
- Measure from this line to the wall, deduct 10mm for clearance from the wall and cut the first row of panels to this size.
- Take this measurement from the overhanging back flange on the long edge of the panel.
- The first panel / tile to be fixed in place must be marked in the middle (600mm side) and positioned on the centre line of the room.
- Line up the edge with the chalk line along the batten.
- Staple fix the first panel / tile in place using five specified staples. The staples are to be fixed parallel to the edge of the panel. Seven staples are recommended for transportable buildings.
- Keep the end staples at least 20mm from the flange heads.
- Nail through the face, close to the wall, using small flat-head galvanised wallboard nails. (It is important that these panel / tile edges are fixed.)
- The Michelangelo Scotia will subsequently cover the exposed nail heads.
- Continue to work both sides, from the centre line, where the first panel / tile was fixed.

- Fit the tongue and grooved joints firmly, but do not force these joints into compression.
- Complete each row before proceeding with subsequent rows.
- Panels / tiles at the ends of each row may require cutting to size.
- Cut last row 10mm undersize.
- Fit this last row of panels / tiles and secure with flat head nails. They will be covered by the Michelangelo Scotia.

## Staple Specification

The following are recommended fasteners for the installation of all wood fibre ceiling panels and tiles.

Hand stapling is recommended with a minimum staple length of 12.5mm minimum with diversion points for fixing into the timber battens.

Table 5 - Staple Supplier Recommendations

<p>Rapid 140 / 12D.P. AB 8014 Bostitch STCR 5019 Haubold KL814</p>
--

## Renovation Work

Wood fibre ceiling panels are particularly appropriate for immediate renovation of old ceilings in sound condition. Battens are generally unnecessary, the panels or tiles being directly stapled to match-lined ceilings or fastened to existing Gibraltar board or fibrous plaster ceilings with the addition of adhesive. Ensure that the old ceiling is flat and firmly secured to the ceiling framing. If in doubt re-fix battens as previously described. With Gibraltar board or fibrous plaster use a "Double Stapling" technique. Refer Fig. 5. This involves holding the hand staple gun steady whilst firing one staple on top of another, the first staple serves as a deflector to spread the legs of the second staple as effective "barbs".

Note: The use of panel adhesive with the stapling system will enhance holding strength.

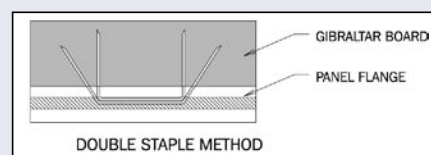

Figure 5. Double Staple Method

Note: Use only 14mm chisel point staples for this method of fixing. For timber backing use single staple method as previously described.

## Finishing

The concealed fastening system used for tongue and grooved ceiling panels and tiles avoids the need for stopping and filling. Wood fibre ceiling panels and tiles have a high quality factory applied undercoat which will readily accept conventional finish coating systems applied to the paint coating manufacturer's instructions. A minimum of one additional top coat is usually required.



## Liability

The Laminex Group will not be liable to any person if the instructions as to storage, use and installation of Shush as outlined in this brochure are not complied with.

Any proprietary products referred to in this brochure must be used in accordance with the relevant manufacturer's instructions. The Laminex Group accepts no liability for these proprietary products.

Nothing contained in this paragraph or elsewhere in this brochure affects any rights a person may have under the Consumer Guarantees Act 1993.

This brochure supersedes all previous issues.

All Acts, Codes and Standards referred to in this brochure are the current editions at the date of brochure publication.



### Health and Safety

#### Health and safety precautions must be taken when working with wood products.

- o Exposure to wood dust may cause irritation to the eyes, respiratory system and skin, and may cause sensitisation resulting in asthma, and by skin contact resulting in dermatitis.
- o Wood dust is classified as a known carcinogen. Repeated inhalation of wood dust over many years may cause nasal cancer.
- o Storage areas containing large quantities of Shush must be adequately ventilated.
- o Work areas must be well ventilated and kept clean. Sawing, sanding and machining equipment must be fitted with dust extractors to ensure that dust levels are kept within standards laid down by Worksafe Australia, Occupational Health and Safety New Zealand, or the specific country of use. If not, a dust mask conforming with AS/NZS 1715 and AS/NZS 1716 and eye protection conforming with AS/NZS 1337 must be worn.
- o Offcuts, shavings and dust must be disposed of in a manner which avoids the generation of dust and in accordance with the requirements of local waste authorities.
- o In end use applications all product surfaces exposed to occupied space must be sealed.

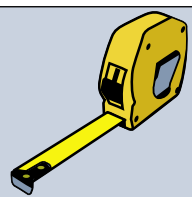

### Technical Support

As not all product use options can be described in this brochure, additional end use and specifying information is available as a complimentary service. The information contained in this brochure must not be reproduced or published in whole or in part without the prior consent of The Laminex Group. The Laminex Group reserves the right to revise without notice any information contained in this brochure. Please contact The Laminex Group Customer Services Department or check The Laminex Group website for up to date information and brochures.

### Contact Details

For more product information or order enquiries please phone  
**The Laminex Group on 0800 303 606** to speak with a representative.  
**[www.thelaminexgroup.co.nz](http://www.thelaminexgroup.co.nz)**

© Copyright reserved, July 2006, The Laminex Group. Shush is marketed, distributed and manufactured by The Laminex Group. A division of FLETCHER BUILDING PRODUCTS LTD.

Shush and the Shush Logo are the trademarks of Fletcher Building Holdings and are used under license by The Laminex Group, a division of Fletcher Building Products Ltd. The Laminex Group and Trade Essentials are trademarks used under license by The Laminex Group, a division of FLETCHER BUILDING PRODUCTS LTD.